



**RESERVOIRS EQUIPES
ASSEMBLED AIR RECEIVERS
TYPE 2RVT150**

**2x150l 30bar vertical
2x150l 435psi vertical
REF.0358230.530A**

Pour tout renseignement complémentaire ne figurant pas dans ce document s'adresser à :
For any further information which does not appear on this document, please enquire to:

GALI FRANCE S.A.

1, rue Barthélémy Thimonnier

Z.I. 66200 ELNE (FRANCE)

Tél. 33(0)4 68 22 20 05 - Fax. 33(0)4 68 22 47 44

e.mail : comfr@gali-france.fr / comexp@gali-france.fr

RESERVOIR EQUIPE ASSEMBLED AIR RECEIVER

2RVT150

CARACTERISTIQUES TECHNIQUES TECHNICAL DATA		
Pression de service maximum Maximum working pressure	bar psi	32 464
Volume Capacity	l l	2x150 2x150
Pression d'utilisation Using pressure	bar psi	30 435
Pression d'épreuve Test pressure	bar psi	49,5 718
Température ambiante Ambiant temperature	°C °F	-10° +50° ⁽¹⁾ 14° +122° ⁽¹⁾
Construction suivant / Réception Build according to / Reception	-	CODAP / CE ⁽²⁾ CODAP / CE ⁽²⁾
Raccordement de remplissage (raccordement femelle gaz Rp) Filling connection (gaz female connection :Rp)	-	1/2" ⁽³⁾ 1/2" ⁽³⁾
Raccordement de sortie (raccordement femelle gaz Rp) Outlet connection (gaz female connection :Rp)	-	1" ⁽³⁾ 1" ⁽³⁾
Alarme pression basse Low pressure alarm	-	Option Optional
Soupape de sûreté Safety valve	-	32 bar laiton CE 464 psi brass CE
Manomètre (marquage à 30 bar) Pressure gauge (30 bar marking)	-	Ø63 cl.1,6 0-60bar Ø63 cl.1,6 0-60bar
Peinture extérieure ⁽⁴⁾ (couleur) Painting external ⁽⁴⁾ (color)	-	RAL5005 ⁽⁵⁾ RAL5005 ⁽⁵⁾
Poids Weight	kg lb	180 396.8

⁽¹⁾ Autre température sur demande.

⁽¹⁾ Other temperature on request.

⁽⁴⁾ Peinture intérieure sur demande.

⁽⁴⁾ Inside painting on request.

⁽²⁾ Autre construction ou réception sur demande.

⁽²⁾ Other build or reception on request.

⁽⁷⁾ Autre couleur ou peinture suivant spécification sur demande.

⁽⁷⁾ Other color or painting according to specification on request.

⁽³⁾ Autre raccordement sur demande.

⁽³⁾ Other connection on request.

Conforme à la directive européenne : 97/23/CE.
According to the european directive : 97/23/CE.

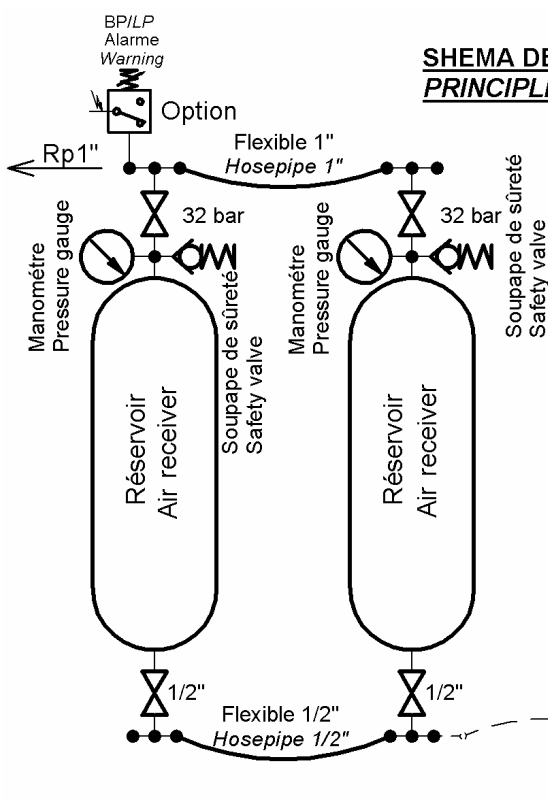

Le réservoir se purge par la purge Automatique du groupe compresseur GALI.
The air receiver is drained by the automatic drain of the GALI compressor set.

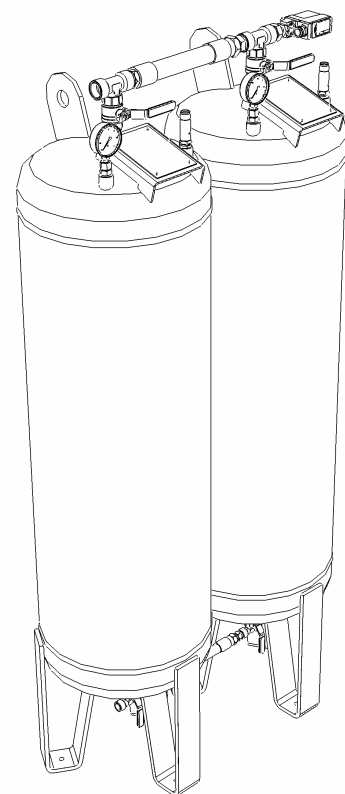

Données techniques sans engagement.
Technical data not binding.

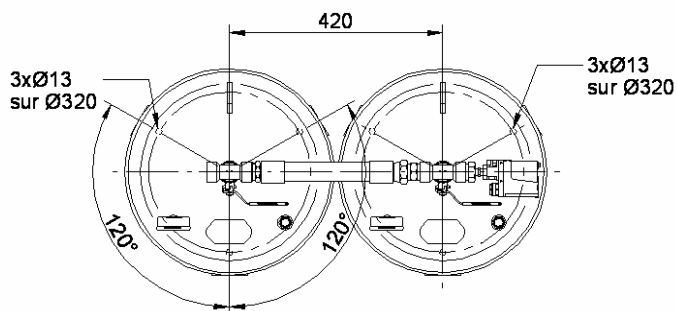
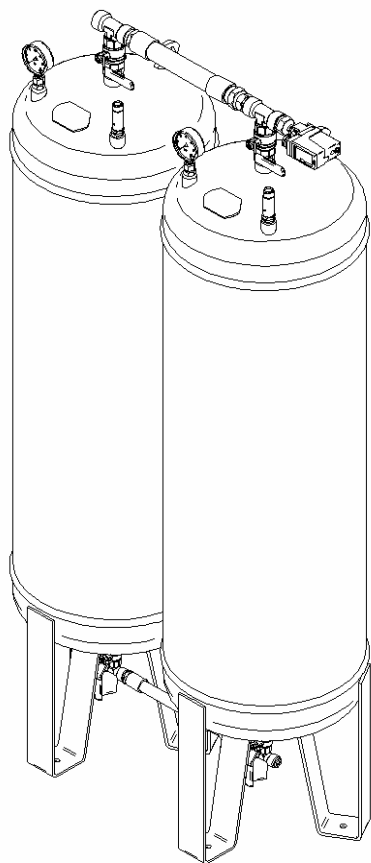
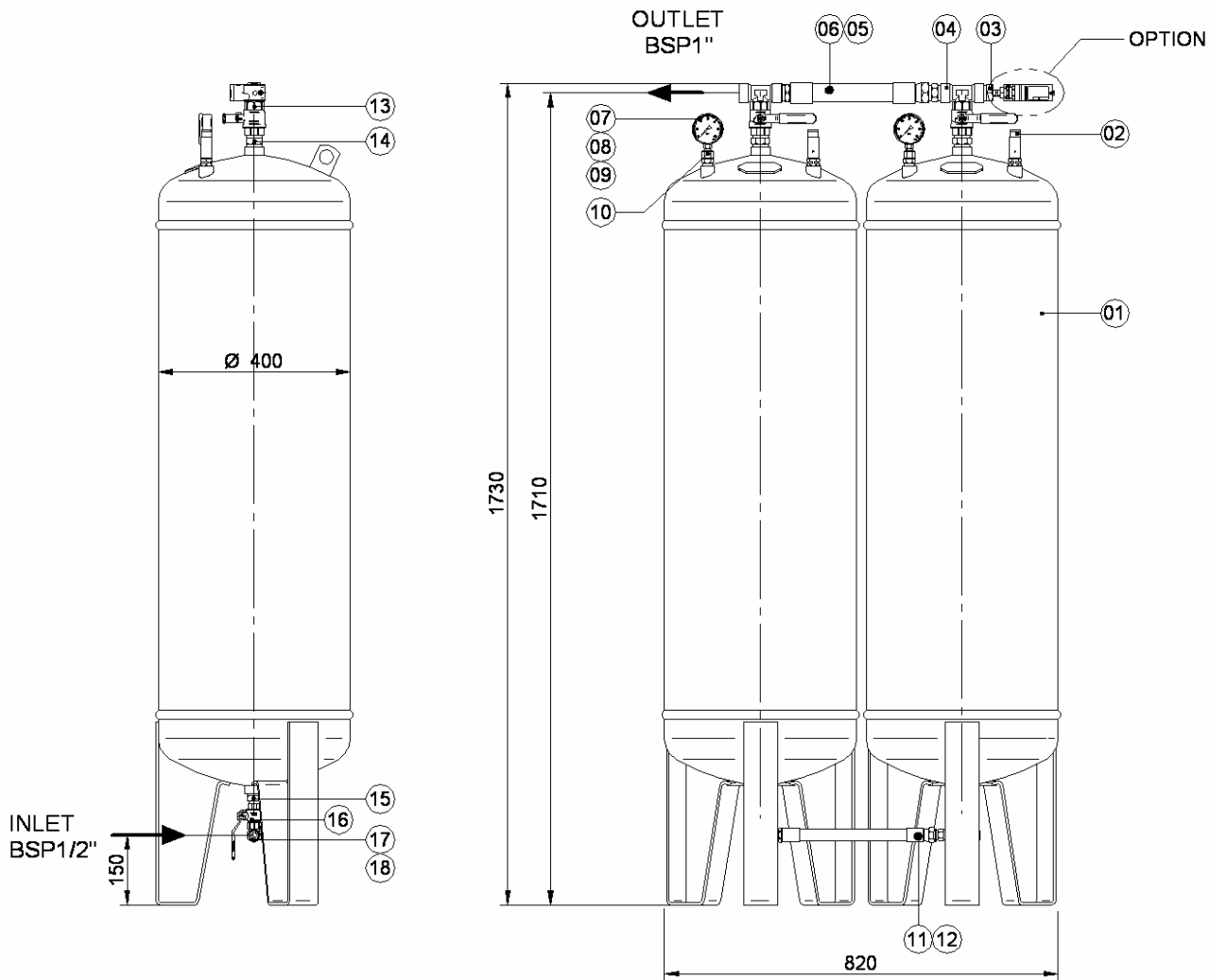

CONSTRUCTION/DESIGNED : 97/23/CE
CAPACITE/CAPACITY : 2x150L
PS/WP : 32 bar
TEMPERATURE: -10/+50°C
POIDS /WEIGHT : 180 kg

IND.	DATE	DETAIL DES MODIFICATIONS	RÉFÉRENCE N°
			0358230.530A
SIEGE & DIRECTION ZI. 66200 ELNE TEL: +33 (0)4 68 22 20 05 FAX: 33 (0)4 68 22 47 44			DATE : 20/03/06
DES. T.BARCELO			PLAN N° 6642 A3
VER. JPS			PAGE : 1/2 IND. a
Ech : 1:10		 RESERVOIR EQUIPE ASSEMBLY AIR RECEIVER TYPE 2RVT150L 32 bar	