

Designed specifically for the
power industry

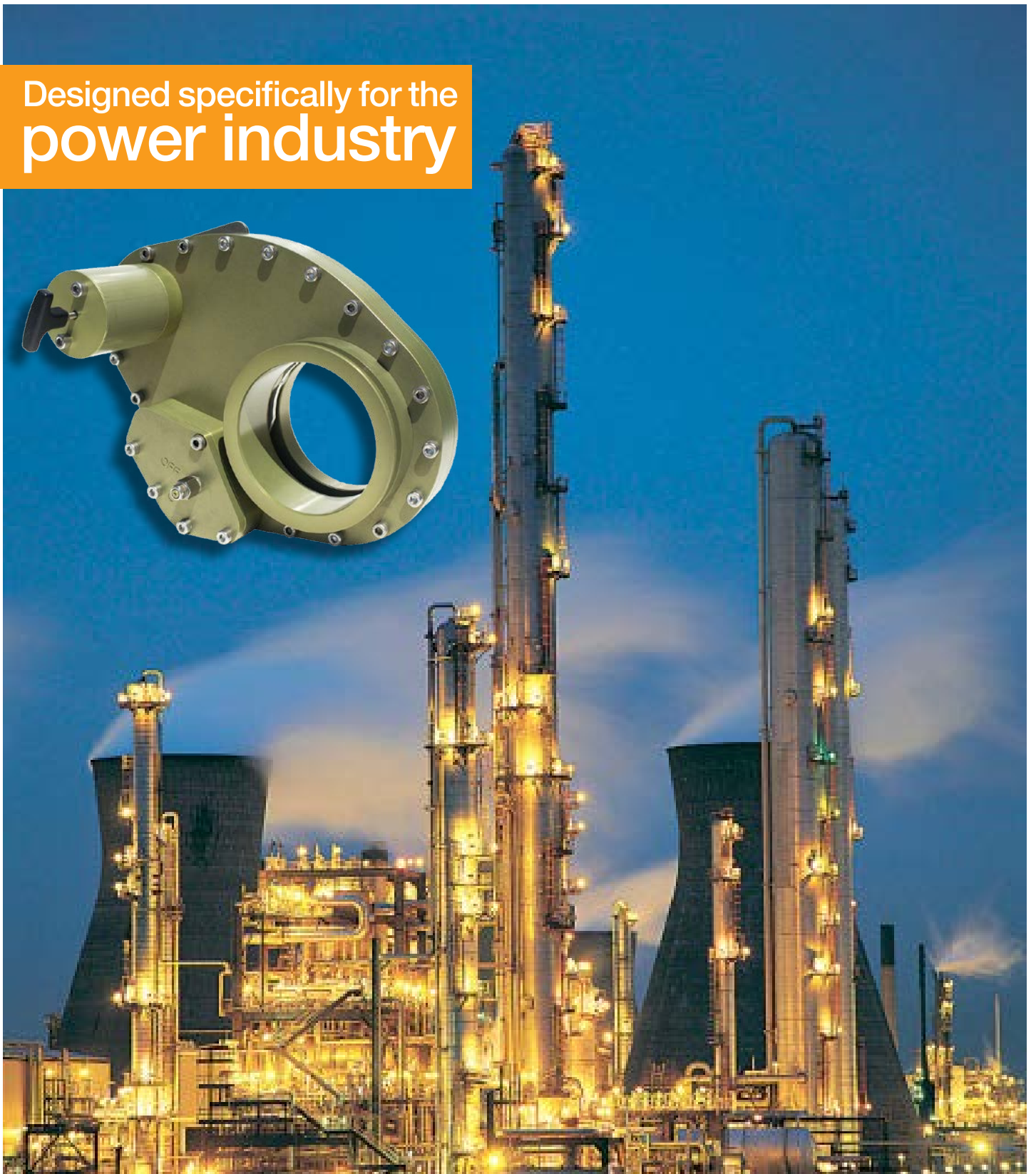
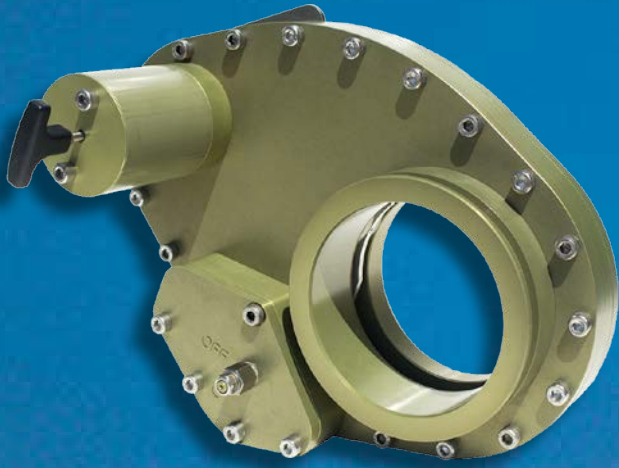

Air Shut Off Valves

Gali

Applications

Hydrocarbons which are potentially present in the atmosphere can become a real problem when attempting to make a controlled stop of an internal combustion engine.

These hydrocarbons may be sucked in by the engine air intake system and produce acceleration and the loss of speed control with the subsequent risk of explosion or deflagration. The ordinary stopping methods (for example, shutting of the fuel flow) may be quite useless, leaving the engine running without any possibility of stopping.

The Gali valve allows the automatic closing of the engine's air intake, increasing safety in places such as offshore oil platforms, engine rooms on-board ships and on land, and petrochemical refineries and plants.

They are also employed for engine isolation in installations of in-line engines with centralised exhaust systems and for closing a wide variety of piping, provided that the actual closing does not have to be fully sealed.

Special versions (eg. ATEX) on request.



Design

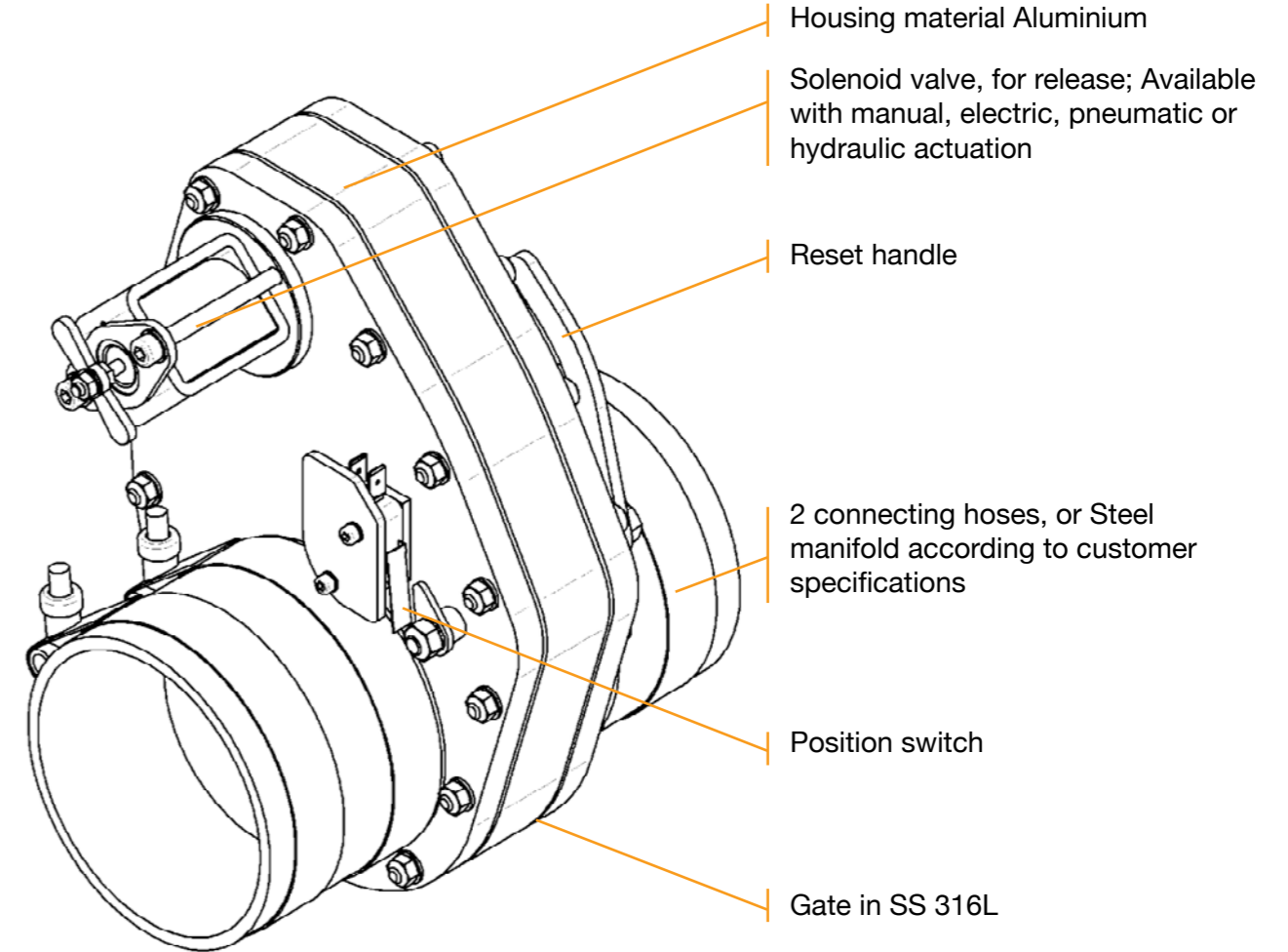

Advantages

- ✓ Special guillotine-design
- Extremely fast closing process
- No impairment of the flow properties
- With the flip closed no pressure conditional opening possible
- ✓ Mountable on the pressure and the suction side
- ✓ Suitable boost pressure max. 5 bar
- ✓ Extremely lightweight design
- ✓ Very compact design
- ✓ Easy installation and handling
- ✓ Wide range of applications up to 13 "(larger on request)
- ✓ Useable in most types of motor
- ✓ On demand with corresponding intake manifolds
- ✓ Operating temperature range -20 °C to +230 °C...

Size	A	B	C	D	E	F	G	H	I
2"	48	57.5	59.5	117	47.5	127.5	175	188	48
3"	71	78	77	155	62	160	222	188	48
5"	127	149.5	122.5	272	104	266	370	200	110
7"	173			366			471		

Shut off valves from 2"-7" dimensions

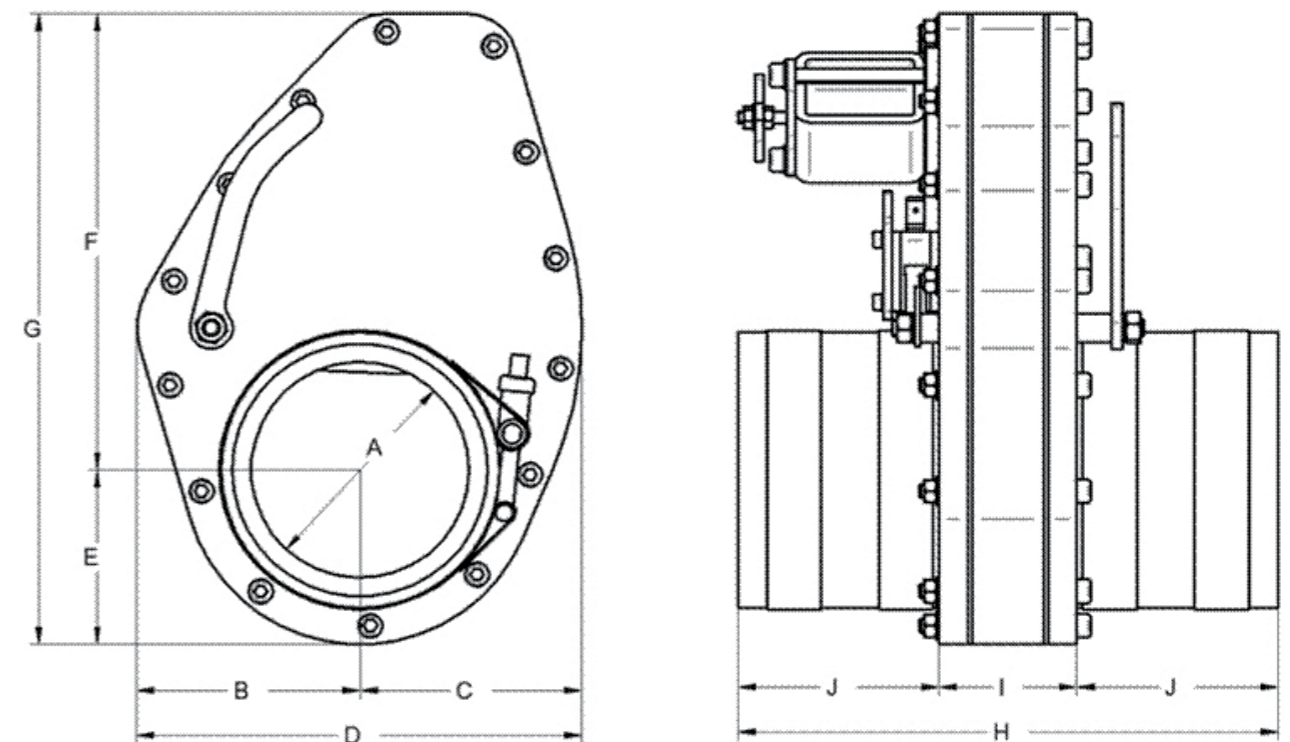

Field applications



Engine: Caterpillar C32

On this engine there are mounted two Shut Off Valves including a new designed manifold.



Motor: MTU 18V BR2000

GenSet for the use in a refinery.

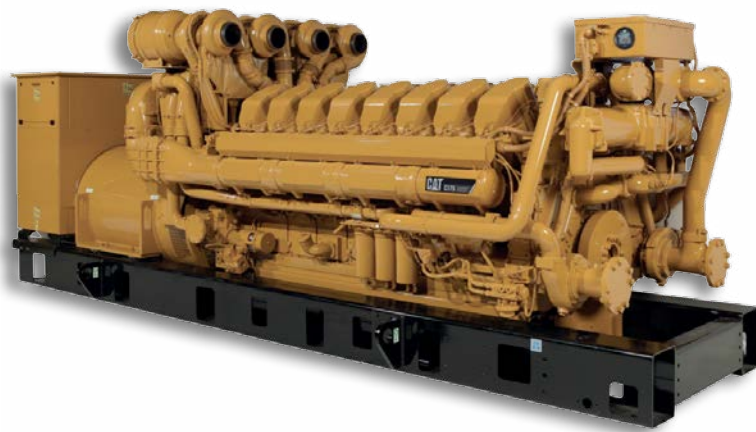

Engine: CAT C175

With 4 Shut Off Valves in line.



Gali

Technical Solutions since 1951

GALI INTERNACIONAL, SA
C/ Josep Tura, 5
08181 Sentmenat (Barcelona)
SPAIN
T +34 93 715 31 11
F +34 93 715 07 51
gali@galigrup.com

GALI DEUTSCHLAND, GmbH
Am Ockenheimer Graben, 32
55411 Bingen
GERMANY
T +49 672 11 00 26
F +49 672 11 31 44
info@gali.de

GALI FRANCE, SA
1, Rue Barthélemy Thimonnier
66200 Elne
FRANCE
T +33 468 22 20 05
F +33 468 22 47 44
comexp@gali-france.fr

GALI CHINA, Ltd.
Jin Hai Road, 6, Building 12, 2F
201206 Pu Dong District (Shanghai)
CHINA
T +86 2158991830
F +86 2158991860
china@galigrup.com

GALI ITALIA, Srl
Via Dante snc
22070 Cirimido (CO)
ITALY
T +39 031 46 12 24
F +39 031 46 12 45
gali@gali-italia.it

www.galigrup.com